

Data sheet - WNS-M3

PEM® Schweißmuttern

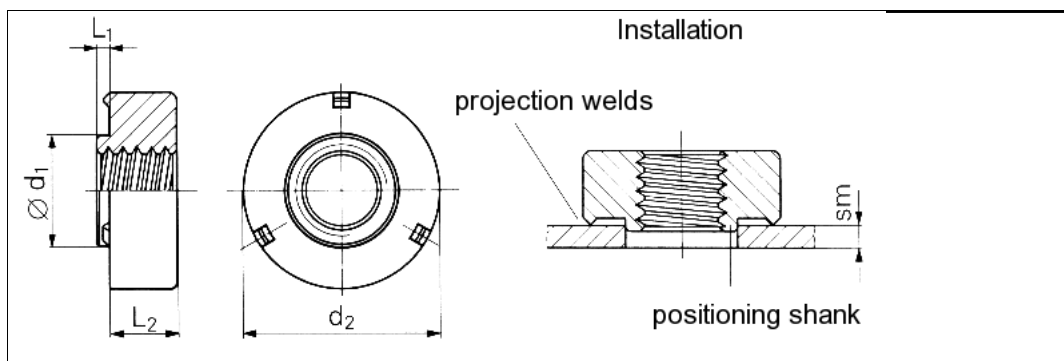

3D-Data available	
Application	Three projection welds guarantee good electrical contact and prevent burn-outs in thin sheets.
	The positioning shank simplifies insertion of the nut and protects the thread against weld spatters.
	Round design specially suitable for automatic feeding.
Order description	WNS-M3
Thread	M3
Max. L1	0.77 mm
Min. sm	0.77 mm
Max. Ø d1	4.36 mm
Hole-Ø in the sheet +0.1 0	4.4 mm
d2 0 -0.25	7.82 mm
L2 ±0.1	1.40 mm
Min. edge distance up to the hole centre	3.90 mm
Material	Passivated stainless steel (AISI 302).

uniform resource locator: