

Technisches Datenblatt - TA-10-075

PEM® TackPin™ Einpressverbinder

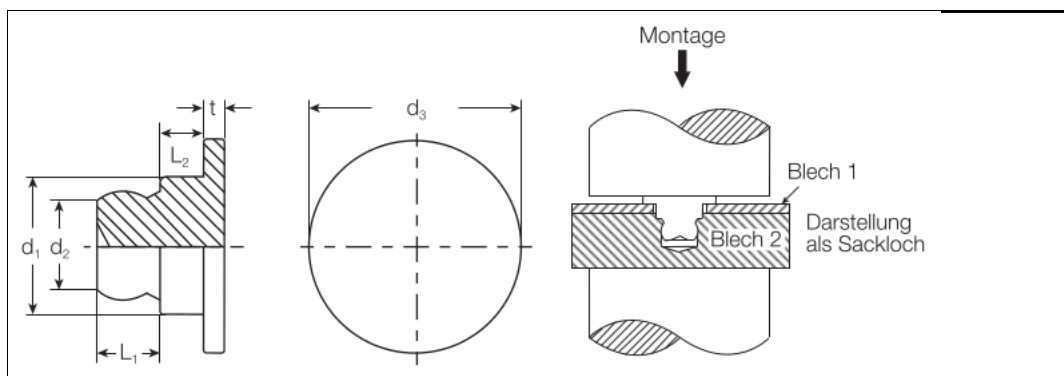

3D-Daten verfügbar	
Ausführung	Für Verbindung zweier Bleche.
Bestellbezeichnung	TA-10-075
Blech 1 sm1	0,71 - 0,79 mm
Blech 1 Ø-Loch ± 0,05	1,47 mm
Blech 2 sm2 min.	0,89 mm
Blech 2 Ø-Loch -0,05	1,02 mm
L1 ± 0,075	0,610 mm
L2 ± 0,025	0,914 mm
d1 ± 0,05	1,30 mm
d2 max.	0,89 mm
d3 ± 0,1	2,00 mm
t ± 0,1	0,20 mm
Min. Randabstand bis Mitte Loch	1,00 mm
Werkstoff	Aluminium
Einsatz	Für Blechhärten bis HRB 45.
Hinweis	Mindestblechstärke von Blech 2 (sm2) bei Sackloch 0,89 mm und bei Durchgangsloch 0,5 mm.
Werkzeuge	
Einpressmaschinen	

Internetadresse: