

Data sheet - SO-M2-12

Self-clinching standoffs

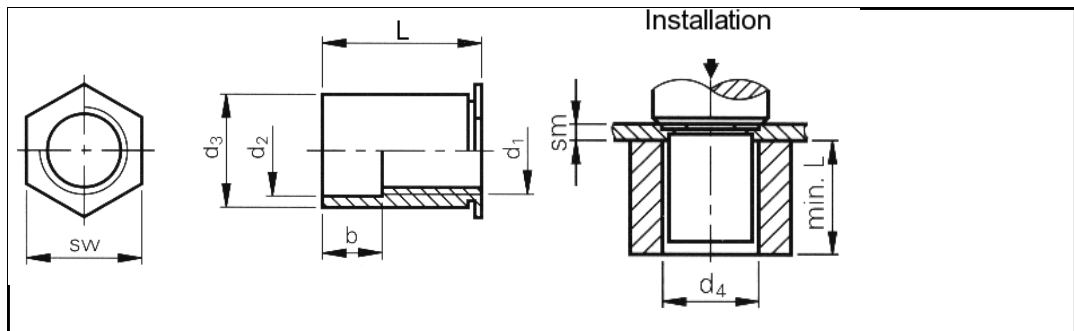

3D-Data available	
Order description	SO-M2-12
Thread d1	M2
Hole-Ø in the sheet +0.08 0	4.2 mm
d2 ±0.13	2.5 mm
d3 0 -0.13	4.20 mm
d4	4.4 mm
sw	4.8 mm
Min. sm	1.0 mm
L +0.05 -0.13	12 mm
Length without threads b ±0.25	4 mm
Min. edge distance up to the hole centre	6.0 mm
Material	Case-hardened zinc-plated carbon steel, bright-finished aluminium on request.
Use	For sheet hardnesses up to HRB 80.
Note	For sheet applications > HRB 80, type SO4 should be used.
Tools	
Insertion machines	

uniform resource locator: