

## Data sheet - SMPS-M2,5

### PEM® Miniatur-Einpressmuttern

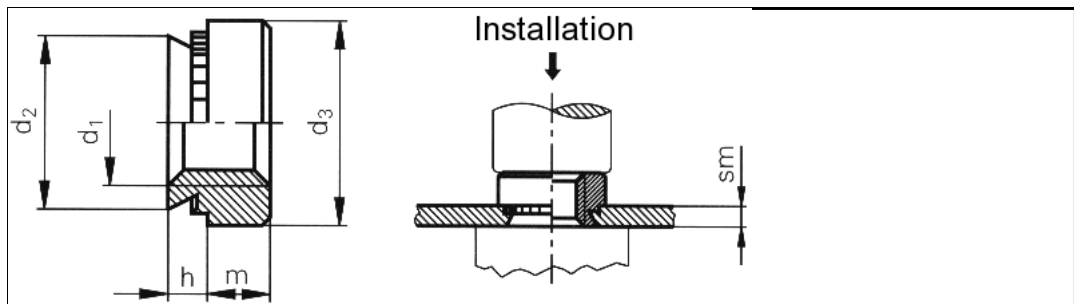

3D-Data available	
Application	For thin sheets from 0.64 mm onwards and for small edge distances.
Order description	SMPS-M2,5
Thread d1	M2.5
Hole-Ø in the sheet +0.08 0	3.80 mm
Max. d2	3.79 mm
d3 ±0.25	5.6 mm
m ±0.25	1.4 mm
Max. h	0.61 mm
Min. sm	0.64 mm
Min. edge distance up to the hole centre	3.7 mm
Material	Passivated grade 18/8 stainless steel (AISI 300).
Use	For sheet hardnesses up to HRB 70.
Tools	
Insertion machines	

uniform resource locator: