

## Technisches Datenblatt - SKC-61,5-14

### Keyhole standoffs

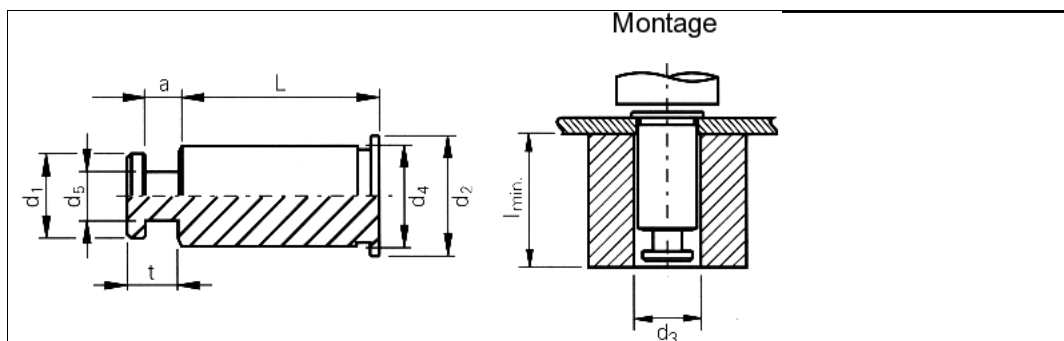

3D-Daten verfügbar	
Bestellbezeichnung	SKC-61,5-14
d1 ±0,08	4,5 mm
d2	6,35 mm
d3 +0,08 0	5,5 mm
d4 max.	5,39 mm
d5 ±0,08	2,51 mm
a ±0,08	1,73 mm
t max.	2,75 mm
L 0 -0,13	14 mm
Werkstoff	Nichtrostender Stahl 18/8 (AISI 300) passiviert.
Einsatz	Für Blechhärten bis HRB 70.
Werkzeuge	
Einpressmaschinen	

Internetadresse: