

Data sheet - PL-M3

PEM® Einpresssicherungsmuttern

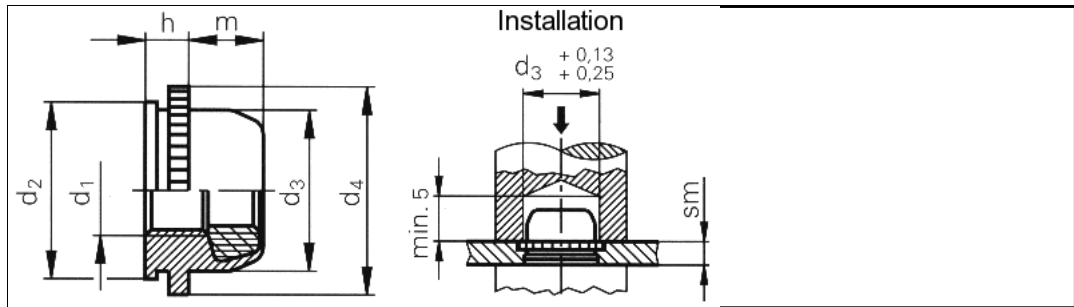

| | |
|--|--|
| 3D-Data available | |
| Application | Self-locking effect due to a nylon ring. Temperature resistant up to + 120 °C. |
| Order description | PL-M3 |
| Thread d1 | M3 |
| Hole-Ø in the sheet +0.08 0 | 6.0 mm |
| Max. d2 | 5.98 mm |
| Max. d3 | 5.52 mm |
| Max. d4 | 7.01 mm |
| Max. m | 3.56 mm |
| Max. h | 1.52 mm |
| Min. sm | 1.5 - 1.8 mm |
| Min. edge distance up to the hole centre | 4.32 mm |
| Material | Case-hardened zinc-plated carbon steel. |
| Use | For sheet hardnesses up to HRB 70. |
| Tools | |
| Insertion machines | |

uniform resource locator: