

## Data sheet - PL-M3

### Self-locking nuts

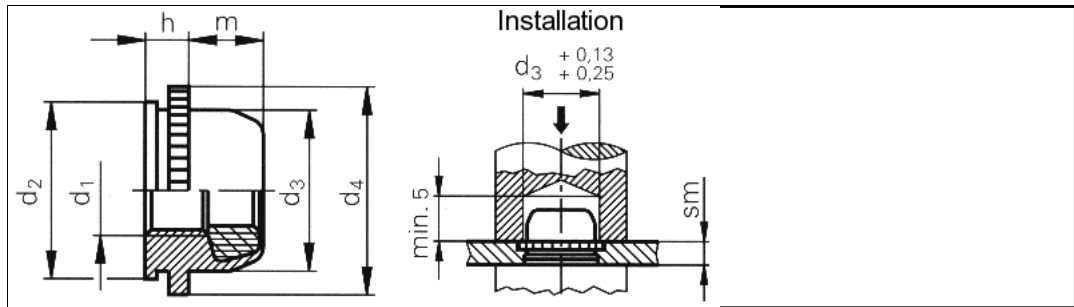

3D-Data available	
Application	Self-locking effect due to a nylon ring. Temperature resistant up to + 120 °C.
Order description	PL-M3
Thread d1	M3
Hole-Ø in the sheet +0.08 0	6.0 mm
Max. d2	5.98 mm
Max. d3	5.52 mm
Max. d4	7.01 mm
Max. m	3.56 mm
Max. h	1.52 mm
Min. sm	1.5 - 1.8 mm
Min. edge distance up to the hole centre	4.32 mm
Material	Case-hardened zinc-plated carbon steel.
Use	For sheet hardnesses up to HRB 70.
Tools	
Insertion machines	

uniform resource locator: