

Data sheet - PFC2-M3-40

PEM® Einpress-Schnellverschlusschrauben

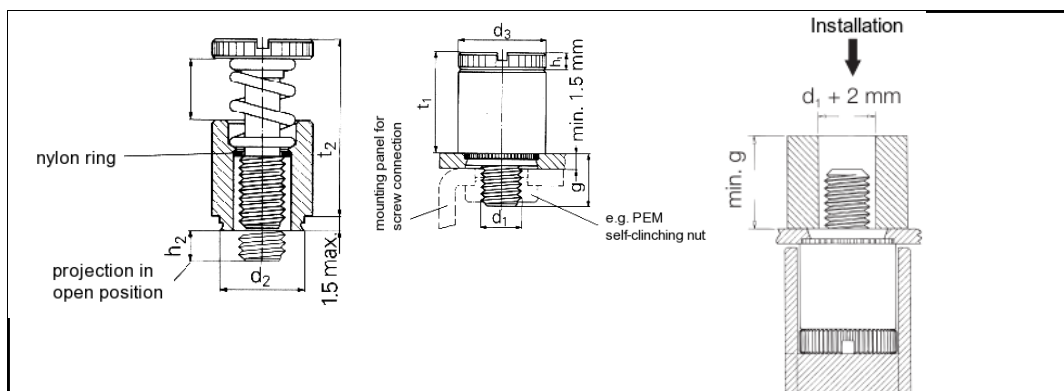

3D-Data available	
Application	Solid self-clinching spring-loaded panel fasteners. Especially as captive screw for quick fixing and dismantling of covers, flaps, etc.
Order description	PFC2-M3-40
Thread d1	M3
Min. sheet thickness	1.5 mm
Hole-Ø in the sheet +0.08 0	6.75 mm
g ±0.4	6.4 mm
h2 ±0.64	0 mm
Max. d2	6.71 mm
d3 ±0.25	7.92 mm
h1 ±0.13	1.83 mm
Max. t1	9.14 mm
t2 nom.	13.7 mm
Min. edge distance up to the hole centre	6.35 mm
Material	Screw, retainer and spring made of passivated grade 18/8 stainless steel (AISI 300).
Use	For sheet hardnesses up to HRB 70.
Tools	
Insertion machines	

uniform resource locator: