

Data sheet - PF11-M3-1

Self-clinching panel fasteners

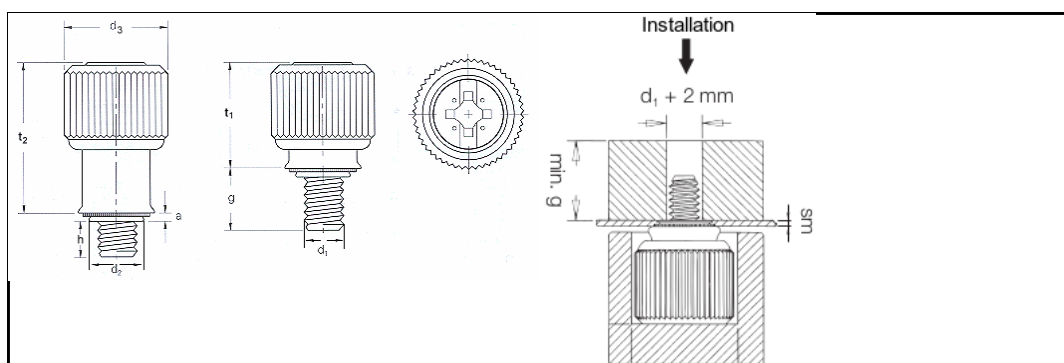

3D-Data available	
Application	Solid self-clinching quick-coupling panel fasteners, spring-loaded with a Phillips cross recess. Especially as captive screw for quick fixing and dismantling of covers, flaps, etc.
Order description	PF11-M3-1
Thread d1	M3
Hole-Ø in the sheet +0.08 0	5.56 mm
Max. d2	5.54 mm
d3 ±0.25	10.59 mm
Max. a	0.92 mm
Min. sm	0.92 mm
g ±0.64	5.84 mm
h ±0.64	1.52 mm
t1 nom.	7.87 mm
t2 nom.	11.43 mm
Min. edge distance up to the hole centre	7.11 mm
Material	Knob made of aluminium, retainer made of nickel-plated steel, screw and spring made of passivated stainless steel.
Use	For sheet hardnesses up to HRB 80.
Tools	
Insertion machines	