

Data sheet - MB 600-080

KOENIG-EXPANDER® Dichtstopfen für Betriebsdrücke bis 450 bar

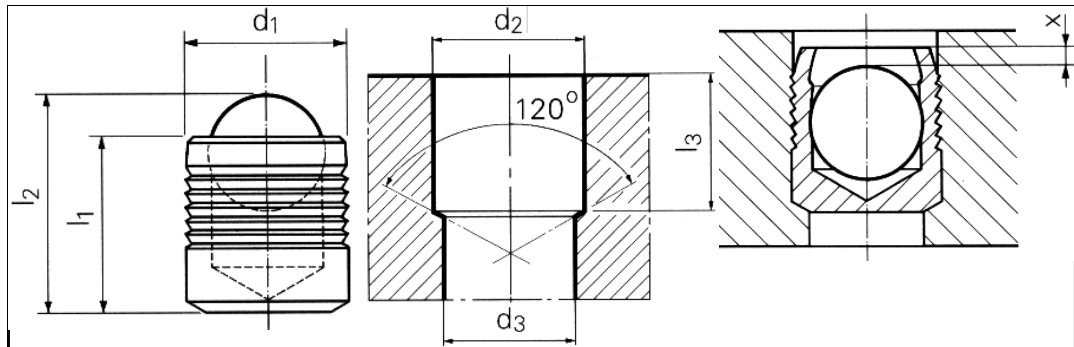

3D-Data available	
Order description	MB 600-080
d1	8.0 mm
l1	8.5 mm
l2 ~	11.55 mm
d2 +0.1 0	8.0 mm
Max. d3	7.4 mm
Min. l3	8.3 mm
x ±0.2	0.3 mm
Sleeve material	Stainless steel
Ball material	Stainless steel
Surface	Sleeve and ball clear passivated per MIL S 5002, aerospace quality
Packaging unit	50 / 250

uniform resource locator: