

Data sheet - FHLS-M2,5-18

PEM® Einpressgewindebolzen für geringe Randabstände

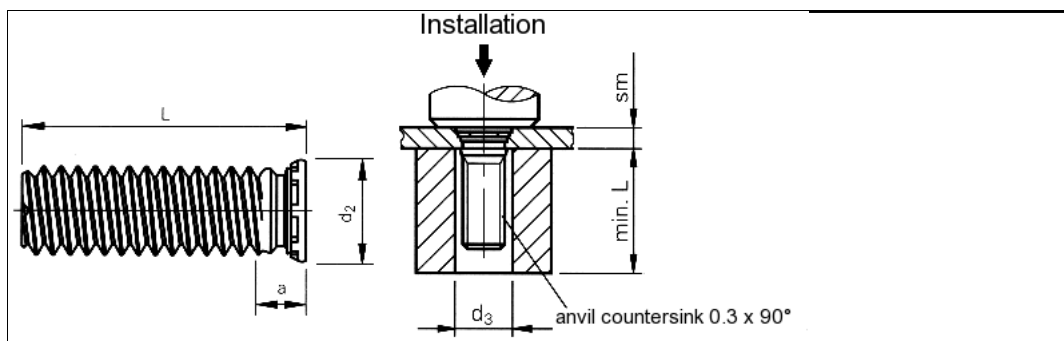

3D-Data available	
Order description	FHLS-M2,5-18
Thread d1	M2.5
Hole-Ø in the sheet +0.08 0	2.5 mm
d2 ±0.4	3.15 mm
d3	2.6 mm
Max. a	2.1 mm
Min. sm	1.0 mm
L ±0.4	18 mm
Min. edge distance up to the hole centre	2.8 mm
Material	Passivated grade 18/8 stainless steel (AISI 300).
Use	For sheet hardnesses up to HRB 70.
Tools	
Insertion machines	

uniform resource locator: