

## Data sheet - FHA-M2,5-18

### Self-clinching flush head studs

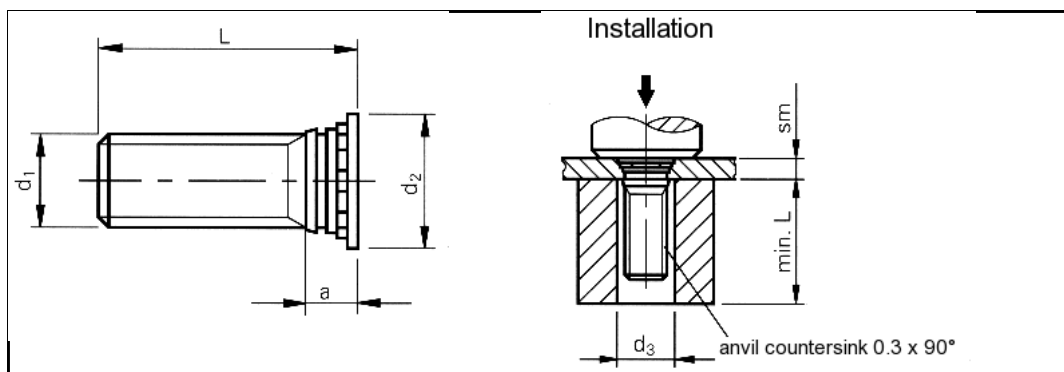

3D-Data available	
Order description	FHA-M2,5-18
Thread d1	M2.5
Hole-Ø in the sheet +0.08 0	2.5 mm
d2 ±0.4	4.1 mm
d3	2.6 mm
Max. a	1.95 mm
Min. sm	1.0 mm
L ±0.4	18 mm
Min. edge distance up to the hole centre	5.4 mm
Material	Bright-finished aluminium.
Use	For sheet hardnesses up to HRB 50.
Information	For thin sheet applications with 0.5 mm use Types TFH (M3 to M5).
Tools	
Insertion machines	

uniform resource locator: