

## Data sheet - F-M2-2

### PEM® Einpressmuttern beidseitig bündig

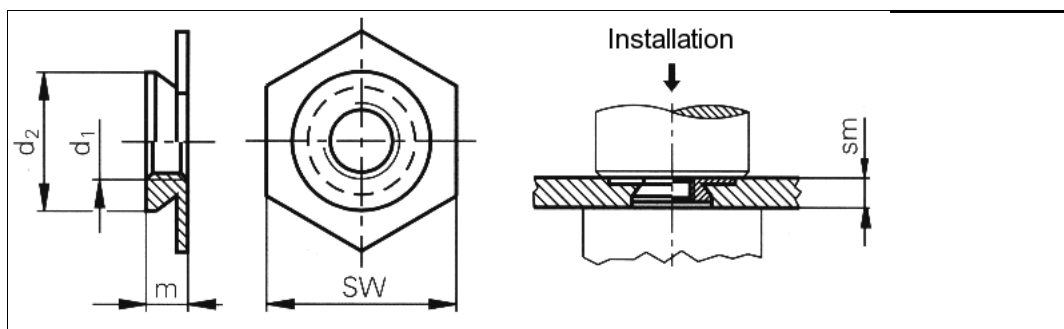

3D-Data available	
Order description	F-M2-2
Thread d1	M2
Hole-Ø in the sheet +0.08 0	4.40 mm
Max. d2	4.35 mm
sw	4.8 mm
Max. m	2.30 mm
Min. sm	2.3 mm
Min. edge distance up to the hole centre	6.0 mm
Material	Passivated grade 18/8 stainless steel (AISI 300).
Use	Specially suitable for thin aluminium sheets (up to a sheet hardness of HRB 70). No protrusions on either surface after installation.
Tools	
Insertion machines	

uniform resource locator: