

## Data sheet - DSOS-M3-7

### PEM® Einpressgewindebuchsen offen

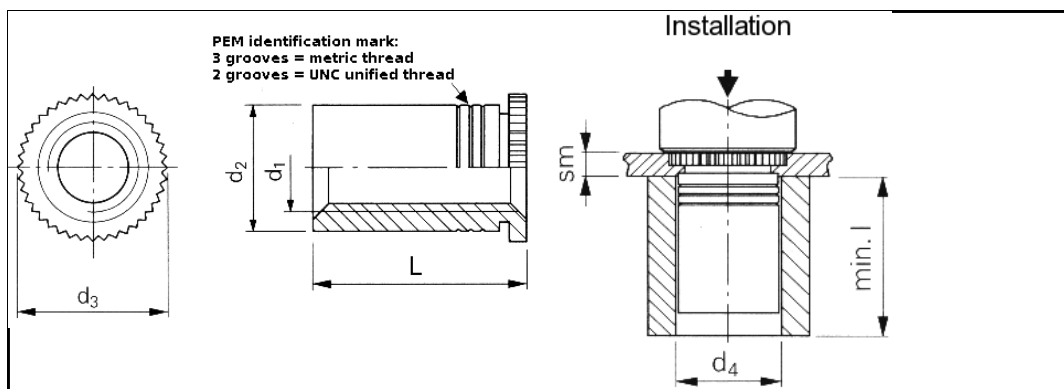

3D-Data available	
Order description	DSOS-M3-7
Thread d1	M3
Hole-Ø in the sheet +0.08 0	4.2 mm
Max. d2	4.19 mm
d3	4.92 mm
d4 +0,2 0	4.3 mm
L +0.05 -0.13	7.0 mm
Min. sm	1.0 mm
Min. edge distance up to the hole centre	3.2 mm
Material	Passivated stainless steel (AISI 300).
Use	For sheet hardnesses up to HRB 70.
Information	Specially designed for D-Sub applications.
Tools	
Insertion machines	

uniform resource locator: