

Data sheet - CSS-M3-4

PEM® Einpressgewindebuchsen für Sacklochmontage

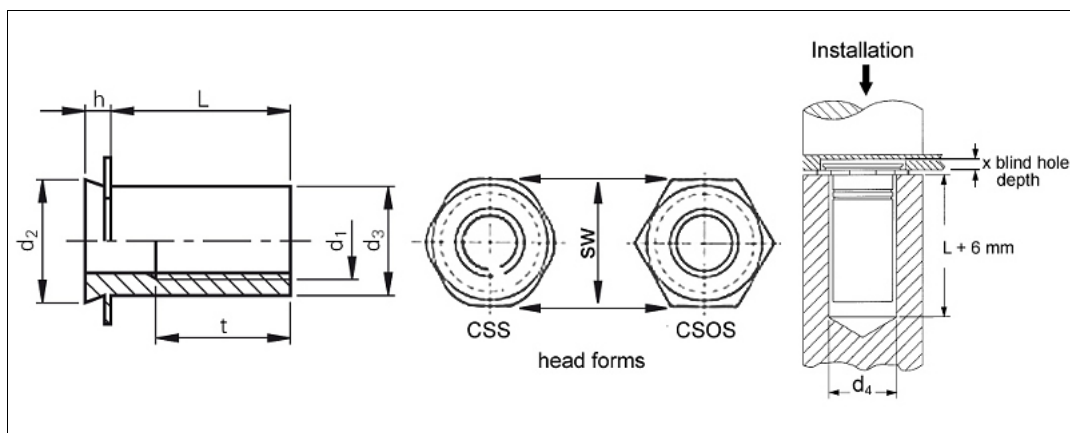

3D-Data available	
Application	For non-visible installation, specially for rating plates, front panels and laminated keyboards.
Order description	CSS-M3-4
Thread d1	M3
Blind hole-Ø in the sheet +0.08 0	5.4 mm
Min. blind hole depth x	1.10 mm
Max. d2	5.39 mm
Max. d3	4.2 mm
d4	4.33 mm
sw ±0.13	6.35 mm
Min. t	5 mm
Max. h	1.04 mm
Min. sm	1.6 mm
L +0.05 -0.13	4 mm
Min. edge distance up to the hole centre	4.8 mm
Material	Passivated grade 18/8 stainless steel (AISI 300).
Use	For sheet hardnesses up to HRB 70.
Note	Standoffs having a length greater than 10 mm are blind at the hex end. Order HSS double-lip centre-cutting milling cutter for the respective diameter.

Tools	
Insertion machines	

uniform resource locator: