

Technisches Datenblatt - CFHA-M3-12

Concealed-head self-clinching studs

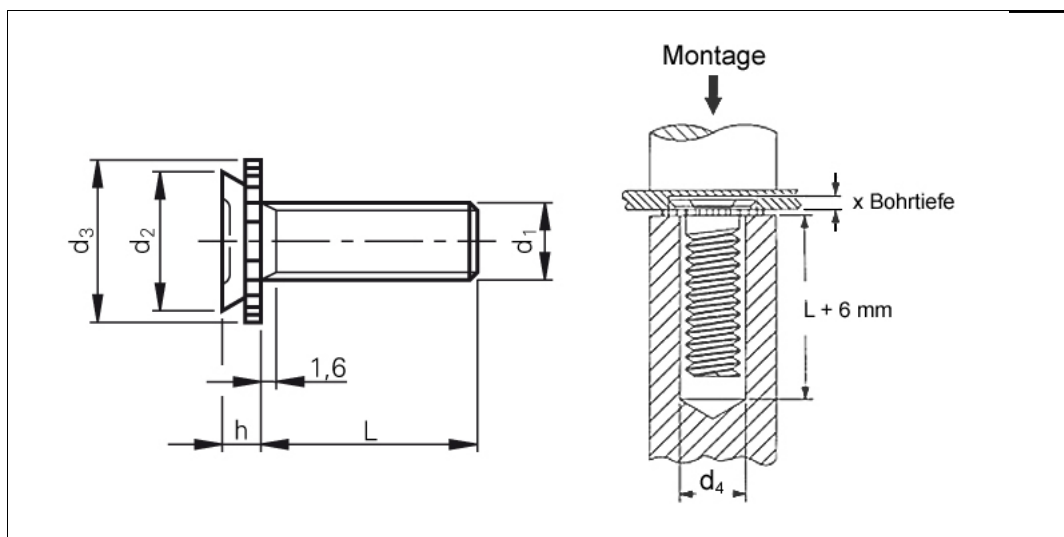

3D-Daten verfügbar	
Ausführung	Für unsichtbare Montage, speziell für Typenschilder, Frontplatten u. Folientastaturen.
Bestellbezeichnung	CFHA-M3-12
Gewinde d1	M3
Sackloch-Ø im Blech +0,08 0	4,4 mm
Bohrtiefe x min.	1,91 mm
d2 max.	4,35 mm
d3 ±0,25	5,21 mm
d4	3,4 mm
h max.	1,80 mm
sm min.	2,4 mm
L ±0,4	12 mm
Min. Randabstand bis Mitte Loch	4,0 mm
Werkstoff	Aluminium
Einsatz	Für Blechhärten bis HRB 50.
Hinweis	Das Bohrloch im Gegenstück (aufzuschraubendes Teil) sollte max. d1 +0,5 mm groß sein. Fräser HSS 2-lippig zentrumschneidend für jeweiligen Durchmesser bestellen.
Werkzeuge	
Einpressmaschinen	

Internetadresse: