

## Technisches Datenblatt - B-M3-1

### Blind self-clinching nuts

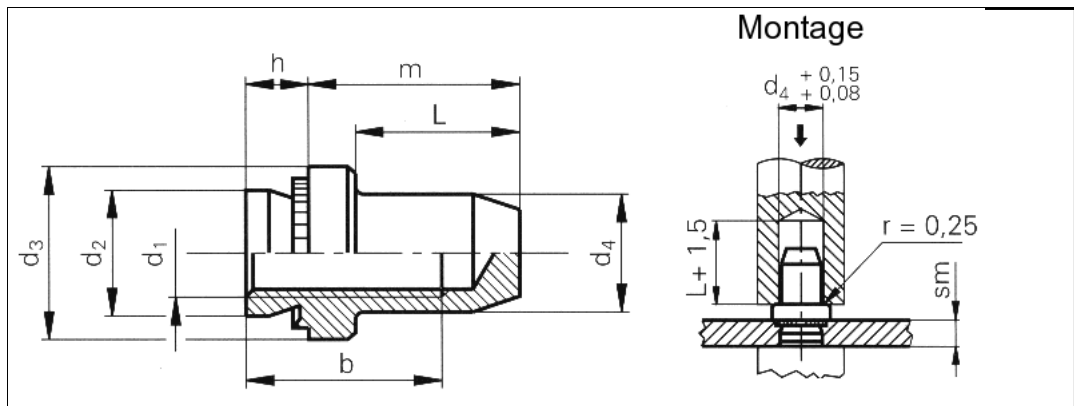

3D-Daten verfügbar	
Bestellbezeichnung	B-M3-1
Gewinde d1	M3
Loch-Ø im Blech +0,08 0	4,25 mm
d2 max.	4,20 mm
d3 ±0,25	6,35 mm
d4 max.	3,84 mm
b min.	5,3 mm
L max.	8,5 mm
m ±0,25	9,6 mm
h max.	0,97 mm
sm min.	1,0 mm
Min. Randabstand bis Mitte Loch	4,8 mm
Werkstoff	Stahl einsatzgehärtet, verzinkt, farblos passiviert.
Einsatz	Für Blechhärten bis HRB 80.
Information	Geschlossenes Gewindeende schützt gegen Verschmutzung usw.
Werkzeuge	
Einpressmaschinen	

Internetadresse: